

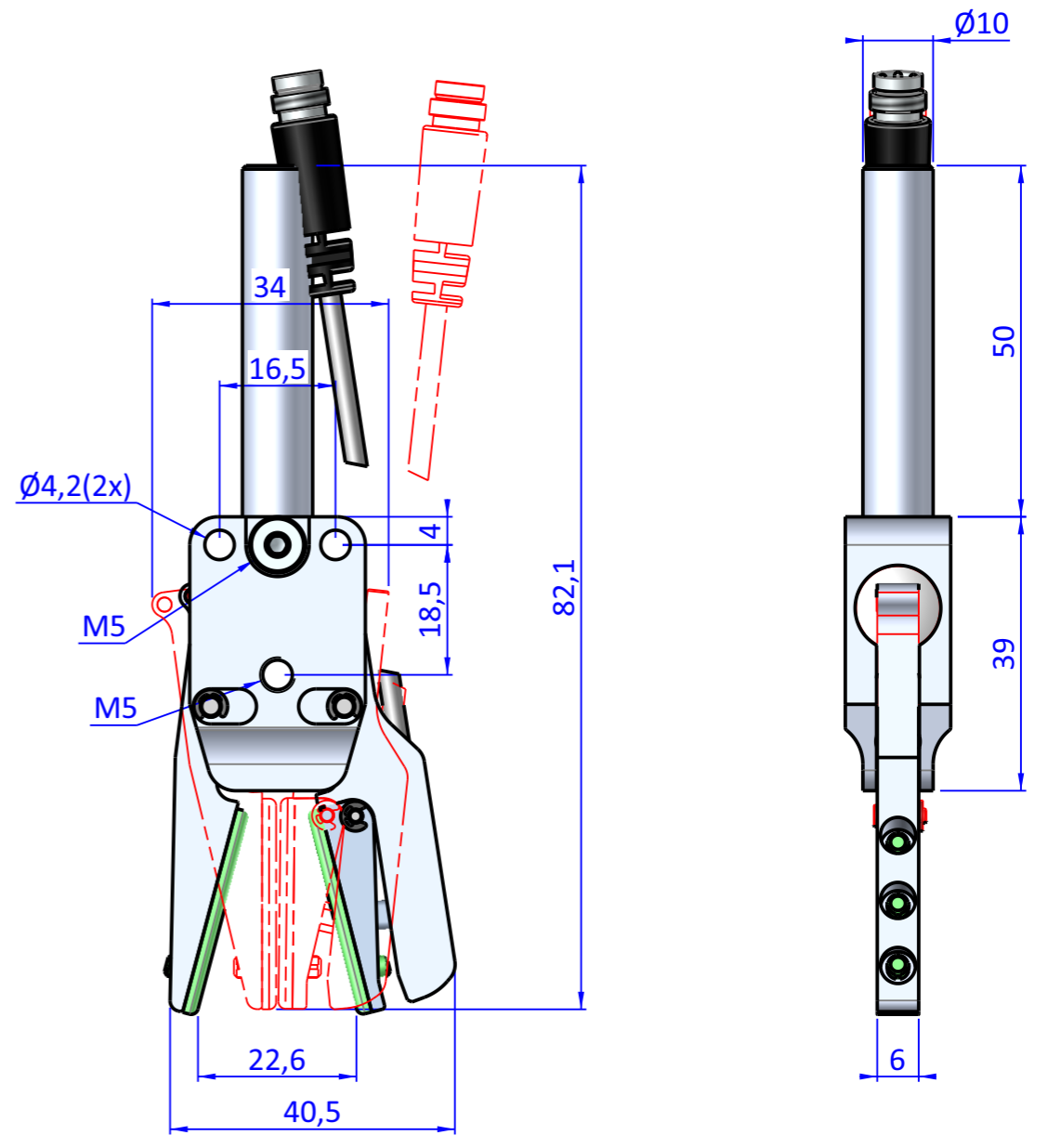

THE PROPERTY OF THE DRAWING IS ESTABLISHED BY LAW. IT IS FORBIDDEN TO PRODUCE OR SHOW IT TO THIRD PART WITHOUT A WRITTEN AGREEMENT.

Item	Name	Qty.
1	A.ELA.RA1.5	1
2	A.ELA.RA1.9	2
3	CA.08.14.013	1
4	DIM.D10620	1
5	GZA.10.08.9	1
6	GZA.10.12.1.50	1
7	GZA.10.12.2.OR	2
8	GZA.10.12.3.G	1
9	GZA.10.12.6.V	2
10	GZA.10.12.9	1
11	GZA.10.12.303	1
12	GZA.10.12.306	1
13	KT58PM8	1
14	M.6x25.SH	1
15	SP.2x7.5SS	1
16	SP.3x15SS	2

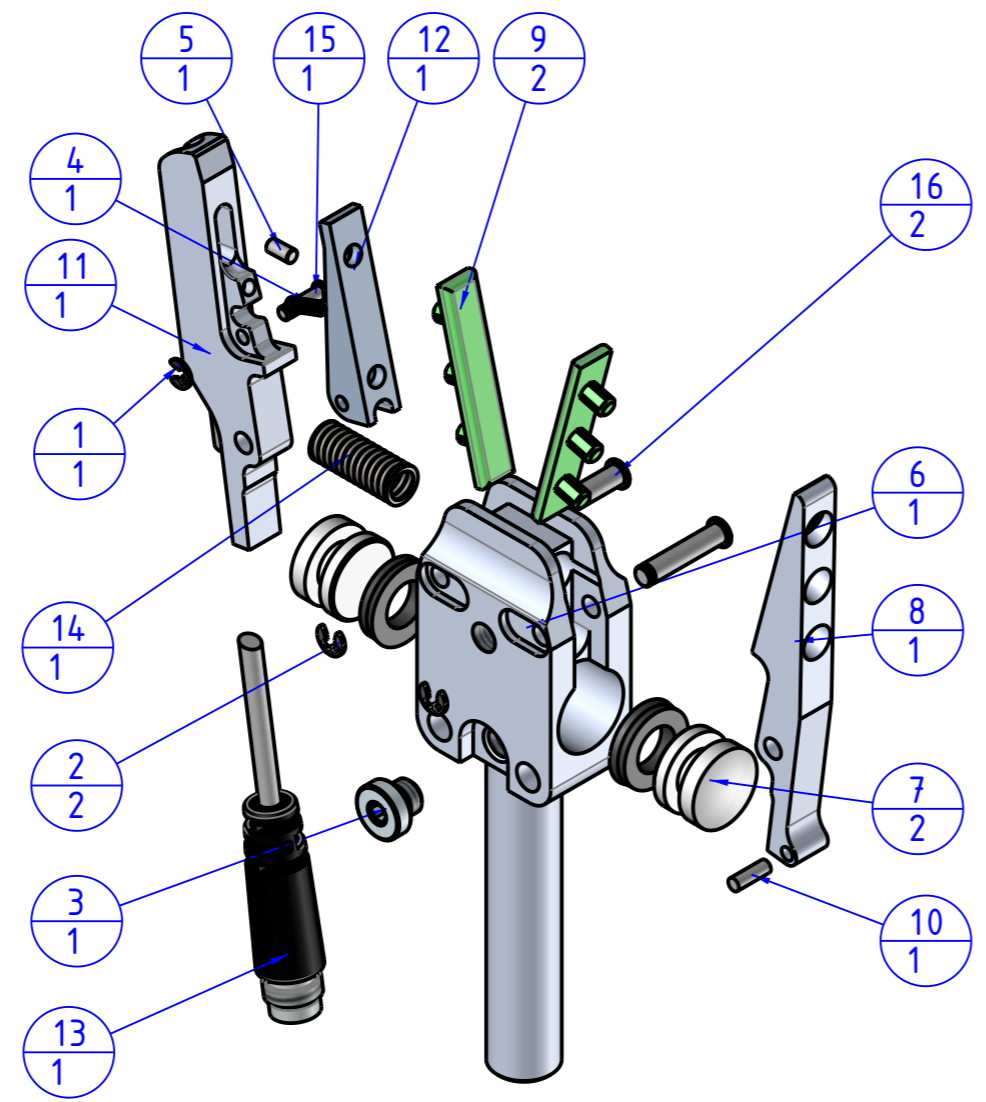

 FPS SERVICES AUTOMATION		DESIGNED FROM		REVIEW
		FPS Automation		A
GENERAL TOLERANCE		DATE	WEIGHT	
UNI - ISO 2768		19/05/2026	0,052kg	
CLASSE f		CODE	CA.GZA.10.12.230	
		CA.GZA.10.12		

Format A3
UNI 936-76